

PANDJIRIS, INC

5151 Northrup • St. Louis, MO 63110 • (314) 776-6893

10,000 LB. CAPACITY WELDING POSITIONER (MODEL 100-12)

The **Model 100-12 MVRMTAB Positioner** has a motorized variable speed rotation with Forward-Stop-Reverse switch and dynamic braking. The rotation speed is variable from 0.025 to .75 RPM with motorized tilt infinitely variable through 135 degrees. A 54" square table with adjustable height to allow full tilting capability is standard. All wiring conforms to National Electrical Code Standards. The positioner operates on 230/460 volt, three phase, 60 cycle input power, draws 39.6 Amps at 230V. When ordering specify 230 or 460 volts. A field changeable plug-in hand pendant includes "Forward-Stop-Reverse-Weld/Rapid" buttons and a speed adjustment potentiometer on 25' of cable as standard.

Load capacity 10,000 lb. 12 inch overhung from face of table, 12 inch eccentricity.
 Rotational motor size 3 H.P. motor.
 Rotation speed Variable from .025 to .75 RPM.
 Rotation torque 120,000 inch pounds.
 Swing radius 39" to 66" @ 90° tilt.
 Tilt range 0 through 135 degrees, motorized tilt.
 Tilt motor size 3 H.P. AC Brakemotor.
 Tilt speed 135 degrees in 45 seconds.
 Tilt torque 201,250 inch pounds inherent.

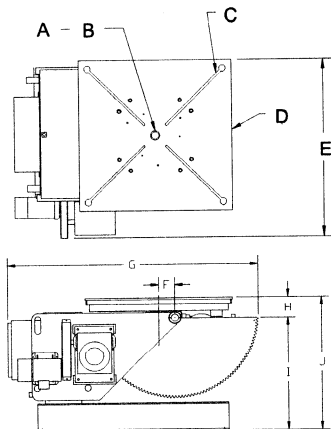

A	Pilot Hole	3"φ x 1/4" Deep
B	Thru Hole	2"
C	"T" Slot Quantity	4
	ANSI Std "T" Nut size	3/4"
D	Table Size	54" sq.
E	Overall Width	66"
F	Rotation Offset	0"
G	Overall Length	98-3/4"
H	Inherent Overhang	8-1/8"
I	Tilt Axis Height	40"
J	Table Height	min 48-1/8"
	(6) Positions	max 78-1/8"

Terms: Pandjiris, Inc. standard terms and conditions apply, f.o.b. Factory, St. Louis, Missouri, or designated ship point.

Delivery: Consult Factory

Approximate shipping weight: 6,000 lbs.

PRICE LIST

For Bulletin No. : PC 0991
 Effective Date : May, 2005
 Page Number : A-21

PANDJIRIS, INC

5151 Northrup • St. Louis, MO 63110 • (314) 776-6893

POSITIONERS Optional Accessories

Foot switch with compatible plug for Forward/Stop/Reverse (speed potentiometer on hand pendant)
Foot switch, Fast-Slow with compatible plug
Preset digital tachometer with compatible plug reads speed in RPM
Dialweld®, (shows linear speed in IPM for diameter set on diameter selector. Dial diameter to be welded, dial weld speed, table RPM is automatically set to weld diameter at selected welding speed) digital meter with compatible plug reads IPM or CmPM
Tach feedback for precision speed control for Models up to 120-12
25' Extension Cable with compatible plugs for standard pendants and accessories
Model 600 PT Copper Welding Ground
Model 1200 PT Copper Welding Ground
For powered elevation of table height consult factory.

Terms: Pandjiris, Inc. standard terms and conditions apply, f.o.b. Factory, St. Louis, Missouri, or designated ship point.

Delivery: Consult Factory

PRICE LIST

For Bulletin No. : PC 0991
Effective Date : May, 2005
Page Number : A-22